

2010

Information Booklet

Contents

| | | |
|------------|--|-----------|
| 1. | Theology Stellenbosch 150+ | 3 |
| 2. | From the Dean's desk... .. | 4 |
| 3. | From the New Dean's desk... .. | 5 |
| 4. | Welcome from the TSC chairperson | 6 |
| 5. | Year Planner | 7 |
| | 1. Opening service | 7 |
| | 2. Theological Day | 7 |
| | 3. Calender 2010 | 7 |
| 6. | Programme 2010 | 7 |
| 7. | Faculty Staff: General [excluding Academic Disciplines] | 14 |
| | 1. Dean's office | 14 |
| | 2. Support staff | 15 |
| | 3. Library | 16 |
| 8. | Faculty Activities | 17 |
| | 1. Dean's Office | 17 |
| | 2. Faculty Board and Faculty Committee | 17 |
| | 3. Dates of Meetings | 17 |
| | 4. Committees of the Faculty | 18 |
| | 5. Boards of Lecturers | 19 |
| | 6. Lecturers Responsible for Year Groups | 19 |
| | 7. Research Development Workshops..... | 20 |
| | 8. Evaluation Meeting (Puntevergadering) | 20 |
| | 9. Doctoral Examinations | 20 |
| | 10. Theological Study Group / Lecturer Prayer Meetings | 21 |
| | 11. Discussion: ECF and the Board of the URC Curatorium | 21 |
| | 12. Krummelkring | 21 |
| 9. | Academic Disciplines | 22 |
| | 1. Old and New Testament | 22 |
| | 2. Systematic Theology and Ecclesiology | 23 |
| | 3. Practical Theology and Missiology | 25 |
| | 4. Extraordinary, Emeriti and Part-time Lecturers | 27 |
| 10. | Church Representation | 28 |
| | 1. Dutch Reformed Church Curatorium/ NG Kerk Kuratorium | 28 |
| | 2. Curatorium Uniting Reformed Church | 29 |
| | 3. Uniting Presbyterian Church of Southern Africa (UPCSA)..... | 31 |
| | 4. Church Liaison Council [CLCUS] | 31 |
| 11. | Student Matters | 32 |

| | | |
|------------|--|-----------|
| 1. | Theological Students Council [TSC] | 32 |
| 2. | Class Representatives | 34 |
| 3. | Where are Our Lectures? | 35 |
| 4. | Tidiness of Venues | 36 |
| 5. | Class Timetables | 37 |
| 6. | Test & Exam Timetables | 39 |
| 7. | General Arrangements regarding Assignments, Tests and Exams | 45 |
| 8. | Bible Knowledge Exam [for all DRC students] | 45 |
| 9. | Theology Library | 45 |
| 10. | Photocopying | 46 |
| 11. | E-learning | 46 |
| 12. | HUMARGA Computer Room | 47 |
| 14. | Available Bursaries | 48 |
| 15. | Spiritual Development and Morning Meditation | 49 |
| 12. | Schematic Representation of Programmes | 50 |
| 13. | Undergraduate Programmes | 50 |
| 1. | General remarks | 50 |
| 2. | BTh in Christian Theology, Church Ministry and Leadership [with Hebrew and Greek] | 50 |
| 3. | BTh in Christian Theology, Church Ministry and Leadership [without Hebrew and Greek] | 51 |
| 4. | Baccalaureus in Theological Studies [BTS] | 51 |
| 14. | Postgraduate Programmes | 51 |
| 1. | General remarks | 51 |
| 2. | Postgraduate Diploma in Theology [PDT] | 51 |
| 3. | MDiv | 51 |
| 4. | Licentiate in Theology | 51 |
| 5. | MTh programme | 51 |
| 6. | DTh programme | 52 |
| 7. | BPhil / MPhil / DPhil in Bible Interpretation | 52 |
| 8. | BPhil / MPhil in Chaplaincy | 52 |
| 15. | Units, Bureaus and Research Centres | 53 |
| 1. | Beyers Naudé Centre for Public Theology [BNC] | 53 |
| 2. | Ekklesia - Bureau for Continuing Theological Education and Research | 56 |
| 3. | Centre for Bible Interpretation and Translation in Africa [CEBITA] | 59 |
| 4. | Unit for Religion and Development Research [URDR] | 60 |
| 5. | Network for African Congregational Theology [NetACT] | 61 |
| 16. | Divisions of Centre for Student Counselling and Development | 63 |

1. Theology Stellenbosch 150+

In 2009 the Faculty of Theology celebrated the 150th anniversary of the day on which the DRC Seminary opened its doors in this building – an important anniversary for theology, but also for the town and university. For the faculty it was important to do justice to this moment. Not only did we want to remember and celebrate theology here and now, but also the past, and particularly the future.

With this anniversary we wanted to commemorate the remarkable heritage of seminary and faculty, as well as the silent voices through the years. And we especially wanted to use this year as the starting point of a future in which the faculty becomes an ever more hospitable space for people from different environments, traditions, experiences and convictions to practise excellent theology. Hence the name of the anniversary year, Theology Stellenbosch 150+.

The year officially started with the Theological Day on 2 February with the theme: Theology in the spiral of memory and hope, and concluded with the memorial service on the exact day, 1 November, on which the seminary opened 150 years ago. In between the year was packed with international conferences, seminars, music and art events, book launches and even an honorary graduation ceremony where five theologians received honorary doctoral degrees.

We thank every member of staff, student and colleague, every alumnus/a, every partner, visitor and supporter who commemorated a remarkable past with us, but even more, helped us to unlock a promising future.

This booklet is for information purposes only. It is to help you orientate yourselves in the Faculty of Theology. Please note, the information in this booklet is subject to change at any time and as such details need to be checked on the university's website and other relevant sources.

2. From the Dean's desk...

Welcome to the Faculty of Theology!

Prof Elna Mouton



Dear Students and Staff,
Welcome to the Faculty of Theology! A special word of welcome to our first year students, and to our new dean, prof Nico Koopman. Welcome to every other student and staff member, our church partners and donors – yes, everyone who shares the exciting challenges of theological training and faith formation today. This booklet has been prepared with care in order to introduce you to people, places and activities at the faculty – enjoy it as a compass to orientate you time and again, also in your prayer life.

The year 2010 promises to challenge the Faculty of Theology in various ways. We are in the process of rethinking and revising our curriculum, including modes of presentation and assessment. We also set out on the journey ahead after we commemorated 150 years of theological training in

Stellenbosch last year.

The motto of the faculty – *sol iustitiae illustra nos* – is a prayer that God, the sun of righteousness, will enlighten us so that we may be able to communicate life and hope amidst complexity and vulnerability. We invite you to be part of the faculty's vision to develop dynamic theological education of a high standard, and to build life-giving relationships according to the nature of the Christian faith.

In tye van sosiale en morele vervreemding wêreldwyd verlang ons om die teenwoordigheid van God te onderskei – in ons klaskamers en kafeteria, kantore, biblioteek en kapel, in mekaar se oë, in die kwaliteit van ons menswees. Daarom nooi ons jou om deel te wees van die fakulteit se visie om in 2010 opleiding van gehalte te verskaf, volgens die aard van die Christelike geloof. Ons roeping is om dinamiese leierskap vir ons tyd te help ontwikkel en om diens aan geloofsgemeenskappe (veral in Afrika) te lewer. Ons het weer eens vanjaar 'n goue geleentheid om die ryk dog komplekse verskeidenheid van verhale, tradisies en standpunte tussen ons te verwelkom en te verreken, en deel van ons gesamentlike verhaal te maak.

Siyanamkela nonke ngovuyo nangesandla esishushu kulo nyaka umtsha. Njengokuba isiXhosa sisithi: gKhanikhulule iibhatyi zenu nizixhome h, sifuna ukuthi: Khanizive ukuba nisekhaya kwiFakhalti yezifundo zakwaLizwi. Siyaniqwenelela ubukho obumangalisayo bukaThixo kunye neentsikelelo zakhe kuyo yonke imizamo yenu.

With very best wishes,

Elna Mouton

(in the Dean's chair until 31 March 2010)

3. From the New Dean's desk...



Die boekie in u hand bevat inligting oor die Fakulteit Teologie. Dit vertel van mense, lesings, vergaderings, toetse, eksamens, resesse, lokale, datums ensovoorts. Hierdie inligting help ons om teologie ordelik, gestruktureerd, planmatig en daarom genotvol te beoefen.

The book is prepared by the office of the Dean, i.e. by the Dean (prof Elna Mouton) and her team of personal assistant to the Dean (me Marieke Brand) and Faculty Manager (rev Liena Hoffman). The word dean originated in the late Roman army of almost two thousand years ago. Besides the army it was later used in church life and in educational institutions. Dean, from the Latin decanus, literally refers to the one who is in charge of ten persons. It referred to those who managed the imperial paper work at home while the emperor was on campaign. It has to do with expertise, leadership and service.

Oor die jare het die begrip verander. Veral in Suid-Afrika en in talle Europese lande verwys die dekaan na die persoon wat die akademiese leiding in 'n fakulteit neem. Dis die persoon wat met haar span ruimte skep waarin die akademie, dit wil sê navorsing, onderrig en gemeenskapsinteraksie, blom. Hierdie boekie uit die dekaanskantoor wil bydra tot die skep van 'n ruimte waarin teologiebeoefening in 2010 blom.

Dis my voorreg om u te verwelkom as aangewese Dekaan, wat op 1 April 2010, amptelik met die dekaansverpligtinge begin. Ná die woelige en opwindende feesjaar van 2009 sien die meeste van ons uit na 'n rustiger 2010. Maar niemand sal die feestelike karakter van 2009 wil vergeet en verloor nie. Ons wil immers teologie as fees beoefen!

'n Spesiale woord van verwelkoming aan ons nuwelingsstudente. Mag julle gou ervaar die fakulteit kan met reg genoem word: ikhaya lethu zonke, 'n tuiste vir almal. En mag julle veel vreugde vind in die nadenke oor die liefde van die drie-enige God vir julleself en vir die ganse wêreld.

In verbondenheid,
Nico Koopman
(in the Dean's chair zfrom 1 April 2010)

4. Welcome from the TSC chairperson

Welcome to the Faculty of Theology!

Helené Fouche: Theological Student Committee (TSC): Chairperson



Ek hoop hierdie jaar is 'n jaar vol goeie herinneringe en akademiese sukses! Ek wil namens die TSK aan elke student, dosent en al die ander personeel sterkte toewens vir 2010; 'n opwindende jaar vir Suid-Afrika en daarom ook vir ons. Noudat al die feesvieringe van die 150-feejaar verby is, mag ons die 'plus' begin en altyd vorentoe leef met hoop!

Die TSK se visie is om hierdie liefde en eenheid verder te bewerkstellig en wesenlik te maak vir al die studente, maar ook almal wat deel is van die Kweek. Mag ons elkeen dit hierdie jaar ons persoonlike taak maak om ons naaste voor onself te ag. Baie sterkte met die jaar en mag dit 'n goeie jaar wees!

Kweekeenheid, Kweekliefde!

Helené

My hope is that this year will be a year filled with memories and academic success! On behalf of the TSC, I would like to wish every student, lecturer and every staff member of the Faculty good luck for 2010; an exciting year for South Africa and therefore also for us. After a very exciting 150 celebration year, may we start the "plus" and always live for the future with hope!

The vision of the TSC for this year is to further establish love and unity in the Faculty and also to make it concrete for every student and everyone else who may be part of the Kweek. May each of us make it our personal undertaking to always think foremost of our neighbour. Good luck for the year, may it be a good one!

Yours in love and unity!

Helené

5. Year Planner

1. Opening service

Date and time: Sunday 24 January 2010 at 19:00

Venue: NGK Stellenbosch-Noord

Conducted by: Johan Cilliers

2. Theological Day

Date and time: Monday 25 January 2010 at 09:00

Venue: Attie van Wijk Auditorium, Faculty of Theology

Theme: Theology, Economy and our Globalising World

3. Calender 2010

NB: This excerpt reflects only the particulars that apply to the Faculty staff and students. For the full calendar [as well as an Afrikaans version], please consult the US web page at <http://web-apps.sun.ac.za/calendar/public/Calendar>. For an Afrikaans Almanak, please consult: <http://www.sun.ac.za/university/dokumente/Almanak2010.pdf>.

6. Programme 2010

| January | |
|-----------------------|---|
| Fri, Jan 1 | NEW YEARS DAY |
| Monday, January 4 | University Office opens Start of Student Intern Training MTh (Clinical Pastoral Care) 1 st day funds available at cost centres 1 st day for placing orders |
| Tuesday, January 5 | Start of intensive Beginners' Course in Afrikaans for international students (to run until 18 January) |
| Monday, January 11 | Start of Theology MDiv degree programme Last day to submit applications for re-admission PRONTAK - Orientation seminar for new lecturers |
| Wednesday, January 13 | Schools in Western Cape begin 1 st year students to report to residences Closing date for admission tests for 1 st year students Start of Welcoming Programme for International Students till 17 January |
| Thursday, January 14 | Introductory programme for newcomer students and their parents (until 23 January)) 10:00 - 11:00 Welcoming of 1 st year students in the DF Malan Centre |
| Friday, January 15 | Last day for loading marks for externally moderated programmes for Nov 2009 exams II Last day for compulsory reading list for 2 nd semester |

| | |
|---------------------------|--|
| Monday, January 18 | 10:00 RBS Registration of newcomer first-year students in Theology 11:00 – 11:30 |
| Tuesday, January 19 | Faculty Committee Meeting 14:00 – 17:00 Registration of newcomer first-year students ends Registration of senior students in Theology 14:00 -15:00 |
| Saturday, January 23 | RAG Official welcoming programme for newcomer first-year students ends |
| Sunday, January, 24 | 19:00 Opening service of the Faculty of Theology at NGK Stellenbosch-Noord |
| Monday, January, 25 | 09:00-13:00 Theology Day: Opening of the Faculty of Theology in Attie van Wyk Auditorium of the Faculty of Theology Classes for newcomer first-year students continue Start of classes for senior students 10:00 RBS |
| February | |
| Monday, February 1 | Last day for publication lists for subsidisation Theological study group / Lecturer Prayer meetings |
| Wednesday, February 3 | Welcoming programme for all post-graduates 15:30 Board meeting Ekklesia |
| Friday, February 5 | Last day for changes to modules and programmes Last day for late registration (excluding new M and D students) |
| Tuesday, February 9 | Faculty Committee Meeting |
| Wednesday, February 10 | SENATE (Research Committee) |
| Thursday, February 18 | 14:30 Faculty Theology Board Meeting Last day for loading of marks for special exams, Masters students and results for Doctoral students for the March graduation |
| Wednesday, February 24 | Krummelkring (Informal conversation event for students and lecturers) Last day for electronic submission of M and D theses for March graduation |
| Thursday, February 25 | Community Interaction Meeting |
| Friday, February 26 | Last day for the submission of M and D applications with full detailed study records, research proposals, bibliographies |
| March | |
| Tuesday, March 2 | Theological study group / Lecturer Prayer meeting |

| | |
|------------------------|---|
| Monday, March 8 | First graduation and Diploma Ceremony: Arts and Social Sciences, Law, Theology, Military Science (16:30) |
| Friday, March 12 | END OF TERM |
| Saturday, March 13 | US RECESS FROM 13–22 MARCH 2010 Music Library: Holiday hours apply Theology Library: Holiday hours apply |
| Sunday, March 21 | HUMAN RIGHTS DAY |
| Monday, March 22 | PUBLIC HOLIDAY US Recess Ends JS Gericke, Health Sciences, Music and Theology libraries closed |
| Tuesday, March 23 | START OF CLASSES FOR SECOND TERM (excluding MB, ChB II–VI) |
| Wednesday, March 24 | MONDAY TIMETABLE TO BE FOLLOWED |
| Friday, March 26 | Last day for applications by international students for admission in second semester |
| Wednesday, March 31 | REGISTRATION OF NEW M AND D STUDENTS End of first term for programmes in Business Management and Administration |
| April | |
| Thursday, April 1 | JS Gericke Library closes at 17:30 |
| Friday, April 2 | GOOD FRIDAY |
| Saturday, April 3 | All libraries closed |
| Sunday, April 4 | EASTER SUNDAY |
| Monday, April 5 | FAMILY DAY (EASTER MONDAY) |
| Wednesday, April 7 | Administrative Committee Meeting (Bedryfskomitee) |
| Thursday, April 8 | Community Interaction Meeting (Gemeenskapsinteraksie) |
| Tuesday, April 13 | Research Committee (Navorsingskomitee) |

| | |
|-----------------------|---|
| Friday, April 16 | Programme Advisory Committee Calendar changes of faculties of Law, Arts and Social Sciences, Education, Economic and Management Sciences, Military Science and Theology) (10:00–14:00) |
| Tuesday, April 20 | Faculty Committee Meeting |
| Thursday, April 22 | Last day for submission to Examinations Section of moderated examination papers for 1st and 2nd examination rounds in May and June |
| Tuesday, April 27 | Freedom Day |
| Friday, April 30 | Last day on which students may officially discontinue modules of first semester at faculty secretaries |
| May | |
| Saturday, May 1 | WORKER'S DAY |
| Monday, May 3 | Theological study group / Lecturer Prayer meeting |
| Thursday, May 6 | 14:30 Faculty Theology Board Meeting |
| Friday, May 7 | END OF CLASSES FOR SECOND TERM |
| Tuesday, May 11 | Start of June examinations (1st round) |
| Friday, May 28 | PAYMENT OF 75% OF STUDENT FEES FOR 2010 Last day on which students, with approval of relevant dean, may change over to extended degree programmes without financial penalty |
| Monday, May 31 | End of June examinations (1st round) Theology Library: End of evening and Saturday services |
| June | |
| Tuesday, June 1 | Start of June examination (2nd round) |
| Monday, June 7 | Theological study group / Lecturer Prayer meeting |
| Monday, June 14 | COUNCIL (14:00) |
| Wednesday, June 16 | YOUTH DAY |
| Friday, June 18 | End of June examinations (2nd round) END OF FIRST SEMESTER, excluding certain programmes at Tygerberg Campus |
| July | |
| Monday, July 12 | Evaluation Meeting |

| | |
|------------------------|--|
| Wednesday, July 14 | Last day for submission of applications for admission in second semester of 2010, excluding readmission applications (which should have been submitted on 10 May) Start of welcoming programme for international students (until 18 July) |
| Friday, July 16 | Last day for loading by departments of class marks and internally and externally moderated final marks for all June examinations, and progress marks for first semester. |
| Monday, July 19 | START OF SECOND SEMESTER |
| Tuesday, July 20 | Research Committee |
| Wednesday, July 21 | Administrative Committee Meeting |
| Thursday, July 22 | Community Interaction Meeting |
| Tuesday, July 27 | Faculty Committee Meeting |
| Friday, July 30 | MODULE AND PROGRAMME CHANGES AND FOR REGISTRATION OF STUDENTS PERMITTED TO RESIDE FROM SECOND SEMESTER SU Open Day Last day for NRF master's and doctoral bursary applications |
| August | |
| Monday, August 2 | Theological study group / Lecturer Prayer meeting |
| Thursday, August 5 | 14:30 Faculty Theology Board Meeting |
| Monday, August 9 | NATIONAL WOMEN'S DAY, PUBLIC HOLIDAY |
| Tuesday, August 10 | MONDAY TIMETABLE TO BE FOLLOWED |
| Thursday, August 19 | First-year Academy Committee (11:00– 13:00) |
| Saturday, August 21 | Access tests for prospective students for 2011 intake |
| Friday, August 27 | SENATE (14:00) |
| Monday, August 30 | Theological study group / Lecturer Prayer meetings |
| September | |

| | |
|---------------------------|--|
| Friday, September 3 | END OF THIRD TERM (excluding certain programmes at Tygerberg Campus). |
| Saturday, September 4 | SU RECESS FROM 4–12 SEPTEMBER 2010 Music and Theology libraries: Holiday hours apply |
| Sunday, September 12 | END OF SEPTEMBER RECESS |
| Monday, September 13 | START OF CLASSES FOR FOURTH TERM (excluding certain programmes at Tygerberg Campus). UNIVERSITY COUNCIL (14:00) |
| Friday, September 24 | HERITAGE DAY |
| Tuesday, September 28 | Faculty Committee Meeting 14:00 – 17:00 |
| Thursday, September 30 | PAYMENT OF OUTSTANDING BALANCES ON TUITION, ACCOMMODATION AND OTHER FEES FOR 2010. Last day for applications by international students for admission in first semester of 2011. Last day for submission of late applications for admission as undergraduate students for 2011, including applications for re-admission Last day on which students may officially discontinue modules of second semester and year modules at faculty secretaries |
| October | |
| Saturday, October 2 | Access tests for prospective students for 2011 intake |
| Monday, October 4 | Theological study group / Lecturer Prayer meeting |
| Thursday, October 7 | Community Interaction Meeting |
| Wednesday, October 13 | Administrative Committee Meeting |
| Tuesday, October 19 | REsearch Committee |
| Friday, October 22 | END OF CLASSES FOR FOURTH TERM Last day for announcement of class marks |
| Tuesday, October 26 | Start of November examinations (1st round) Faculty Committee Meeting |
| November | |
| Monday, November 1 | Theological study group / Lecturer Prayer meetings |
| Thursday, November 4 | 14:30 Faculty Theology Board Meeting |

| | |
|---------------------------|--|
| Wednesday, November 17 | End of November examinations (1st round) End of Examinations for Licentiate (Theology) Music and Theology libraries: End of evening and Saturday services |
| Friday, 19 November | Last day for loading by departments of final marks for Licentiate (Theology) (12:00) Last day for submission of foreign bankers drafts for imports |
| Tuesday, November 23 | Last day for loading by departments of final marks of first round of November examinations Announcement of examination results for Licentiate (Theology) |
| Wednesday, November 24 | Admission of Dutch Reformed Church and Uniting Reformed Church students (18:00) |
| Friday, November 26 | Senate (14:00). |
| Saturday, November 27 | Access tests for prospective students for 2011 intake |
| December | |
| Saturday, December 4 | End of November examinations (2nd round) |
| Monday, December 6 | FIRST GRADUATION CEREMONY: Education and Theology (17:30) |
| Tuesday, December 7 | Last day for loading by departments of internally moderated final marks for non-final-year modules of November examinations (2nd round) (12:00) |
| Friday, December 10 | END OF SECOND SEMESTER |
| Thursday, December 16 | RECONCILIATION DAY |
| Monday, December 20 | Last day for applications for admission to postgraduate programmes, excluding master's and doctoral programmes, unless indicated otherwise in relevant section of Calendar |
| Friday, December 24 | University offices close (12:45) |
| Saturday, December 25 | CHRISTMAS DAY |
| Sunday, December 26 | DAY OF GOODWILL |
| Monday, December 27 | PUBLIC HOLIDAY |

7. Faculty Staff: General [excluding Academic Disciplines]

1. Dean's office





| | | |
|------------------------------|---|---|
| Dean | <p>Prof Elna Mouton [Room 1024] Tel. 808-3254 E-mail: emouton@sun.ac.za (Until 31 March 2010)</p> |  |
| | <p>Prof Nico Koopman [Room 1024] Tel. 808-3254 E-mail: nkoopman@sun.ac.za (From 1 April 2010)</p> |  |
| PA to the Dean | <p>Marieke Brand (Botha) [Room 1020] Tel. 808-2142 E-mail: mariekeb@sun.ac.za</p> |  |
| Faculty Manager | <p>Rev CH (Liena) Hoffman [Room 1024] Tel: 808-3261 E-mail: liena@sun.ac.za</p> |  |
| Receptionist & Admin Officer | <p>Me Karin Linders (Room 1020) Tel: 808 3255 E-mail: karinl@sun.ac.za</p> |  |
| Admin Officer (part-time) | <p>Me Helette van der Westhuizen Tel: 808 2469 E-mail: hvdwest@sun.ac.za</p> |  |

| | | |
|-------------------|---|---|
| Faculty Secretary | <p>Mr Shirle Cornelissen Tel. 808-4850 E-mail: shirle@sun.ac.za</p> |  |
|-------------------|---|---|

2. Support staff

| | | |
|--|--|---|
| Assistant Mail & Facilities | <p>Mr Howard Ruiters Tel. 808-3534 Cel: 072 512 7493</p> |  |
| Assistant Photocopying & Facilities | <p>Mr Mark Koopman Tel. 808-3253 E-mail: wjk@sun.ac.za</p> |  |
| Assistant Curatorium & Facilities | <p>Mr Joseph Fillies Tel. 887-6819 808-3534 E-mail: fillies@sun.ac.za</p> |  |
| Assistant Facilities | <p>Ms Jenny Fortein Tel. 808-3253</p> |  |
| Assistant Facilities | <p>Ms Minnie Philander Tel. 808-3253</p> |  |

3. Library

| | | |
|---|--|---|
| Head | Ms Beulah Gericke Tel. 808-3508 E-mail: bg1@sun.ac.za |  |
| Subject enquiries | Mrs Susanne Botha Tel. 808-3252 E-mail: sbot@sun.ac.za |  |
| Lending desk, General Enquiries and distance education students | Ms Annemarié Eagleton Tel. 808-3507 E-mail: jme@sun.ac.za |  |
| Lending desk and general enquiries | Ms Theresa Jooste Tel. 808-3252 E-mail: ts3@sun.ac.za |  |

8. Faculty Activities

1. Dean's Office

The Dean's office is primarily concerned with the planning and promotion of academic excellence, liaising with the SA Board, Church Liaison committees and students. The management of the Faculty, including personnel well-being, finances and infrastructure is also part of the responsibilities of the Dean's office.

2. Faculty Board and Faculty Committee

The Faculty Board is the body that co-ordinates and controls all activities of the Faculty. It is the highest decision and policy making body in the Faculty. The Faculty has four core committees: Administration Committee (Bedryfskomitee) and three academic committees: Community Interaction, Teaching and Learning (Komitee vir Leer en Onderrig) & Research and Publications (Navorsing en Publikasies). The Board functions in synchronisation with the different core faculty committees and the Faculty Executive Committee. The meetings are scheduled as follows: Firstly, the different committees convene [in time to hand in their written reports to the Faculty Secretary for consideration by the Faculty Committee]. Thereafter the Faculty Committee convenes to consider the different reports and to make their recommendations to the Faculty Board. Finally, the Faculty Board convenes to make decisions on such recommendations.

The timeous submission of committee reports to the Faculty Secretary is therefore very important. It is the responsibility of the chairpersons of the different committees to submit the written reports. Reports should consist of two parts

i] Recommendations and Matters of Notification [published in the same form in the Faculty Board Agenda];

ii] Full reports, i.e. Argumentations, motivations etc. [published as addenda in the Faculty Board Agenda].

3. Dates of Meetings

| SUBMISSION OF WRITTEN REPORTS | SPECIAL FACULTY COMMITTEE 14:00 | FACULTY COMMITTEE MEETING 14:00 | FACULTY BOARD MEETING 14:30 |
|--|--|--|--|
| 15 January 2010 | 19 January 2010 | 9 February 2010 | 18 February 2010 |
| 13 April 2010 | | 20 April 2010 | 6 May 2010 |
| 23 July 2010 (note: first week of semester 2) | | 27 July 2010 | 5 August 2010 |
| | 28 September 2010 | | |
| 19 October 2010 | | 26 October 2010 | 4 November 2010 |

| | | | |
|--|--|--|--|
| | | | |
|--|--|--|--|

4. Committees of the Faculty

| COMMITTEE | MEMBERS | MEETINGS |
|--|---|--|
| Administrative Committee (Bedryskomitee) | Dean Faculty Manager TSC Representative Administrative Representative (Ms M. Brand) Support Staff Representative (Mr J. Fillies) Secretary (Ms K. Linders) | Wednesday 7 April 2010 at 14:00 Wednesday 21 July 2010 at 14:00 Wednesday 13 October at 14:00 |
| Community Interaction (Gemeenskaps-interaksie) | Prof Kalie August [C] Ms Liena Hoffman (ONT) Ms Marieke Botha [EGON] Dr Anita Cloete (PT&M) Prof Louis Jonker [SEBIVA] Dr Clint Le Bruyns (TE) Ms Anlené Taljaard [BNC] Ms Helené Fouché (TSC) Dr Coenie Burger (Ekklesia) Prof Jurgens Hendriks (NetACT) | Thurs 25 Feb 2010 at 15:00 Thurs 8 Apr 2010 at 15:00 Thurs 22 Jul 2010 at 15:00 Thurs 7 October 2010 at 15:00 |
| Teaching & Learning Committee (Leer en Onderrig) | Prof Hendrik Bosman [C] Dean Prof Jeremy Punt Prof Johan Cilliers Dr Gerrit Brand Dr Ian Nell Dr Eddie Orsmond [BUCTER] Faculty Manager or E-learning Coordinator Representative of TSC | Wednesday 14 April 12:50 Wednesday 21 July 12:50 Monday 18 October 12:50 |
| Research and Publications Committee (Navorsing en Publikasies) | Prof Dirkie Smit [c] Prof Nico Koopman (as dean) Prof Louis Jonker Dr Xolile Simon Dr Clint Le Bruyns Dr Coenie Burger Ms Beulah Gericke (library) Ms Wilma Riekert (Secretary) | Tues 13 April 2010 at 13:00 Mon 18 July 2010 at 13:00 Tues 5 October 2010 at 13:00 |
| Additional Committees | | |
| Alpha programme [welcoming of 1st years] | Prof Nico Koopman Representative of TSC | Per arrangement |

| | | |
|---|--|--|
| Ecumenical and International Committee | Prof Jeremy Punt [Coordinator] Prof Jurgens Hendriks Prof Nico Koopman Representative of TSC | Per arrangement |
| Coram Deo | Nico Koopman Elmé Bosman Johan Cilliers Marí Britz Denise Ackermann Ian Nell Andrew Snyders Natie Philander David Hunter | 13:00 in Chapel: 31 March 28 July 6 October |
| Student Liaison Committee | The Dean liaises with the TSC | Jointly with TSC meetings |
| Theological day, Theological Study group, Faculty Discussion | Dr Robert Vosloo [Coordinator] Dr Gerrit Brand | Per arrangement |

5. Boards of Lecturers

| BOARD | MEMBERS | MEETINGS |
|--------------------|---|-----------------|
| DRC Lecturer Board | Chair: Dr Robert Vosloo Secretary: Prof Ian Nel All DRC lecturers | As arranged |
| URC Lecturer Board | Chair: Dr Xolile Simon All URCSA lecturers | As arranged |

6. Lecturers Responsible for Year Groups

| | |
|------------|---------------------|
| BTh I | Dr Ian Nell |
| BTh II | Prof Louis Jonker |
| BTh III | Prof Jeremy Punt |
| BTh IV | Prof Johan Cilliers |
| MDiv | Dr Ian Nell |
| Licenciate | Prof Kalie August |

7. Research Development Workshops

The research and development programme of the Faculty of Theology is now 7 years old. It aims at building research capacity among current and prospective postgraduate students of theology. It is co-ordinated and conducted by Dr Clint Le Bruyns in collaboration with other colleagues and the faculty's research committee.

Monthly workshops are held at the Faculty of Theology and cover various topics respectively, such as developing a research proposal; methodology and methods; guidelines for oral examinations; time-management; using the internet in research; the literature review; role-relations between supervisor and student; presenting your research in public; getting your research published; research ethics; etc.

2010 Research Development schedule (09h00-14h00):

| | | | | | |
|-------|-------|-------|-------|---------|----------|
| Feb 5 | Mar 5 | Apr 9 | May 7 | June 4 | July 1-2 |
| Aug 6 | Sep 3 | Oct 1 | Nov 5 | Dec 1-3 | |

The monthly workshop topics will be advertised via e-mail, FT website, facebook (research development forum), and on FT bulletin boards. All are welcome but RSVP is strictly required for workshops. For more details, contact Dr CC Le Bruyns (clb@sun.ac.za / 021 808-2913).

8. Evaluation Meeting (Puntevergadering)

The last date upon which marks [class, final and progress] for the first semester can be loaded onto the system is 16 July 2010. Consequently, the Evaluation Meeting will be on 12 July at 14:00 in the *Dosenteraadsaal* (with internal and external evaluators' reports regarding final modules).

The last day upon which internally and externally moderated marks for the first round of November examinations (with a view to the December graduation) can be loaded is 23 November 2010. 7 December 2010 is the last day for loading non-final year modules November examination, second round. Consequently, the Evaluation Meeting will be on Monday 26 November at 10:00 in the *Dosenteraadsaal*.

The licentiate marks need to be in on the 19th of November 2010. Therefore, the Evaluation meeting for the November exams will be on 23 November 2010.

9. Doctoral Examinations

Regarding doctoral examinations the results have to be confirmed at the last Faculty Board meeting on 4 November 2010. Consequently, examinations have to be finalised before this date in the event of the candidate wanting to graduate at the December graduation.

The date for submission for examination of theses and dissertations is the 1 August 2010 with a view to the December 2010-graduation; and 1 December 2010 for the March 2011 graduation.

10. Theological Study Group / Lecturer Prayer Meetings

1 February: Johan Cilliers
2 March: Ian Nell
3 May: Nico Koopman
7 June: Jeremy Punt
2 August: Julie Claassens
30 August: Gerrit Brand
4 October: Xolile Simon
1 November: Louis Jonker

11. Discussion: ECF and the Board of the URC Curatorium

Every first Wednesday of the month 12:00-13:00

| | | | | | | | |
|-------|-------|-------|---------|-------|-------|-------|-------|
| 7 Feb | 7 Mar | 2 May | 25 July | 1 Aug | 5 Sep | 3 Oct | 7 Nov |
|-------|-------|-------|---------|-------|-------|-------|-------|

12. Krummelkring -Social meeting between students and lecturers

| | | | | | |
|---------|----------|----------|-------|---------|--------|
| 10 Febr | 10 March | 14 April | 4 May | 28 July | 18 Aug |
|---------|----------|----------|-------|---------|--------|



9. Academic Disciplines

1. Old and New Testament

Focus

The focus of Old and New Testament is on the solid, responsible and accountable interpretation of the Bible. Theological exegesis of the Bible is accountable to the rest of the academic scholarly community and to the communities of faith [in Africa and abroad] where the interpretation of Scripture takes place. Therefore the Hebrew and Greek texts of the Bible need to be interpreted taking cognisance of the world of the Biblical authors [then] and readers [now]. In continuity with the Biblical text itself, the interpretation is aimed at liberation and healing of the church and the community.

Staff

| | | |
|---------------|---|---|
| Old Testament | Prof Hendrik Bosman [Chair] [Room 2025] Tel. 808-3267 [w] E-mail: hlb1@sun.ac.za |  |
| | Prof Louis Jonker [Room 2026] Tel. 808-3268 [w] E-mail: lcj@sun.ac.za |  |
| | Prof Julie Claassens [focus on Human Dignity] [Room 2022] Tel: 808- 3255 [w] E-mail: jclaassens@sun.ac.za |  |

| | | |
|------------------------|--|---|
| New Testament | <p>Prof Elna Mouton [Room 1024/ 2023] Tel. 808-3255 [w] E-mail: emouton@sun.ac.za</p> |  |
| | <p>Prof Jeremy Punt [Room 2024a] Tel. 808-2615 [w] E-mail: jpunt@sun.ac.za</p> |  |
| Administrative Officer | <p>Ms Felicity Grové [Room 2024] Tel. 808-3626 [w] E-mail: fg@sun.ac.za</p> |  |

2. Systematic Theology and Ecclesiology

Focus

Ecclesiology is the theological-scientific study of the history and the order of the church. Special focus and study is given to the African and South African context and to the Reformed tradition.

Systematic Theology studies Christian Faith as well as Christian Ethics. In Christian faith the content of the Christian tradition - often summarised in confessions and doctrines concerning God [including God's revelation and knowledge of God, God's creation, God's providential care, God's image, humankind], Jesus Christ [including his person, life and work of salvation] and the Holy Spirit [including the life-giving work of the Spirit, the church, the sacraments, the ends of creation] - is studied in the light of contemporary questions, claims and experiences.

In Ethics the foundation of Christian morality is researched. It is often summarised in questions about what morality is and how it can be founded, what constitutes a moral society, how moral people behave, what moral actions are in view of specific ethical questions, and whether Christians should adhere to a particular form of morality.

Personnel

| | | |
|------------------------|---|---|
| Systematic Theology | <p>Prof Nico Koopman [Room 2011/ 1024] Tel. 808-3262 [w] E-mail: nkoopman@sun.ac.za</p> |  |
| | <p>Prof Dirkie Smit [Room 2010] Tel. 808-3258 [w] E-mail: djs1@sun.ac.za</p> |  |
| | <p>Dr Clint le Bruyns [Room 1005A] Tel: 808 - 2913 E-mail: clb@sun.ac.za</p> |  |
| Ecclesiology | <p>Dr Robert Vosloo (Chair) [Room 2006] Tel: 021 808-3256 [w] E-mail: rrvosloo@sun.ac.za</p> |  |
| | <p>Dr Mary-Ann Plaatjies van Huffel [Room 2011] Tel: 808-3255 E-mail: mapvanhuffel@sun.ac.za</p> |  |
| Administrative Officer | <p>Ms Wilma Riekert [Room 2005] Tel. 808-3576 [w] E-mail: wriek@sun.ac.za</p> |  |

3. Practical Theology and Missiology

Focus

In the discipline group Practical Theology and Missiology we try to understand how the Word and acts of God take shape in the words and deeds of man in the world. We try to understand what it means to be sent out by God to the world where we live and work. How do we cross the boundaries of culture, race, class, gender, place and age to reach those in need? Theology is words and the witnesses about God. When we see and hear God, He guides us to the needs of our neighbours. What are these needs? What causes these needs? How do we deal with them? How do we equip leaders and members, congregations, to become involved in God's mission [Jn. 3:16] to the world? These are the questions that we ask; on these issues we do our research, and for this task we train people.



In the light of these questions, Practical Theology deals with the issues of church ministry, the life of faith communities in different contexts, and the transformative actions within society [development].

The homiletical process of the church service embedded in liturgical rituals forms the meeting point between God and humankind. We also focus on spirituality development, pastoral care, diaconal outreach, missional involvement, inculturation, as well as contemporary youth questions.

Staff

| | | |
|------------|--|---|
| Missiology | Prof Kalie August (Chair) [Room 2018] Tel. 808-3856 [w] E-mail: kta@sun.ac.za |  |
| | Dr Xolile Simon [Room 2014] Tel. 808-3636 [w] E-mail: dsimon@sun.ac.za |  |

| | | |
|--------------------|---|---|
| Practical Theology | <p>Prof Johan Cilliers [Room 2017] Tel. 808-3264 [w] E-mail: jcilliers@sun.ac.za</p> |  |
| | <p>Prof Daniël Louw Tel. 887-1703 [h] E-mail: djl@sun.ac.za (until March 2010)</p> |  |
| | <p>Dr Ian Nell Tel. 808-9094 [w] Email: ianell@sun.ac.za</p> |  |
| | <p>Prof Jurgens Hendriks Tel: 8083260 E-mail: hjh@sun.ac.za</p> |  |
| | <p>Ms Elmé Bosman [Room 1017] Tel. 021-886 9771 [w]</p> |  |
| Pastoral Care | <p>Dr Christo Thesnaar [Room 2016] Tel: 808-3257 [w] E-mail: cht@sun.ac.za</p> |  |

| | | |
|---|---|---|
| Youth Ministry | <p>Dr Anita Cloete [Room 2018] Tel: 808- 2614 E-mail: acloete@sun.ac.za</p> |  |
| <p>Temporary Administrative Officer</p> | <p>Ms Annalina Vlok-Smith [Room 2012] Tel. 808-3577 [w] E-mail: ptm@sun.ac.za (until end April)</p> |  |

4. Extraordinary, Emeriti and Part-time Lecturers

Extraordinary Professors

Prof JC Breytenbach (Old and New Testament)
Prof JW van Henten (Old and New Testament)
Prof GD Cloete (New Testament)
Prof J de Gruchy (Systematic Theology)
Prof BR Gaventa (New Testament)
Prof Y Gitay (Old Testament)
Prof K Holter (Old Testament)
Prof E Noort (Old Testament)
Prof SB Reid (Old Testament)
Prof VK Robbins (New Testament)
Prof A Van de Beek (Systematic Theology)
Prof HJ Stipp (Old and New Testament)
Prof ER Wendland (Ancient Studies and Old and New Testament)
Prof AA Boesak (Systematic Theology)
Prof H Bedford-Strohm (Systematic Theology)
Prof F De Lange (Systematic Theology)
Prof LJ Koffeman (Systematic Theology)
Prof WF Storrar (Systematic Theology)
Prof JWV Van Huyssteen (Systematic Theology)

10. Church Representation

1. Dutch Reformed Church Curatorium/ NG Kerk Kuratorium

Focus

The Dutch Reformed Church [DRC] Curatorium is the governing body that oversees the theological training of the DRC candidates. The Curatorium is represented by approximately 20 representatives from all the synodical regions of the DRC. The Curatorium meets every year during November. Rev Monty Sahd, the Minister responsible for Theological Training, is the contact person for the Curatorium and the co-ordinator of all the Committees of the Curatorium.

Staff

| | | |
|---|---|---|
| Chair | Dr Coenie Burger [Room 2000] Tel. 808-3624 [w] E-mail: cwbu@sun.ac.za |  |
| MSS: Theological Training and Secretary | Rev Monty Sahd [Room 1008] Tel. 887-6819/6828 [w] E-mail: mpsahd@sun.ac.za |  |
| Secretary | Ms Dawida du Plessis [Room 1009] Tel. 887-6819/6828 [w] E-mail: dadp@sun.ac.za |  |
| Treasurer | Ms Estelle van der Merwe [Room 1013] Tel. 887-6819/6828 [w] |  |
| Assistant | Mr Joseph Fillies Tel. 887-6819/6828 E-mail: fillies@sun.ac.za |  |

Committees of the Curatorium

| COMMITTEE | ACTIVITIES | | | | | | | | | | | | | | | | | | | | | | | | | | | | | | |
|--|---|-------------|---------------------|---------------------|--------------------|-------------|-------------|---------------------|-------------|-------------|------------------|-------------|-------------|------------------|-------------|-------------|----------------|-------------|-------------|-----------------|-------------|-------------|-------------------|-------------|-------------|-------------------|-------------|-------------|--------------------|-------------|-------------|
| Executive | Convenes on a monthly basis – deals with urgent matters on behalf of the Curatorium. | | | | | | | | | | | | | | | | | | | | | | | | | | | | | | |
| Mentoring Committee | Responsible for the pastoral mentoring and evaluation of theological students under the leadership of Rev Marie Britz. | | | | | | | | | | | | | | | | | | | | | | | | | | | | | | |
| Bursary Committee | Responsible for annual awarding of bursaries and loans on behalf of the Curatorium. | | | | | | | | | | | | | | | | | | | | | | | | | | | | | | |
| Examinations Committee | Responsible for the annual examinations of candidate ministers, reporting to the Curatorium. | | | | | | | | | | | | | | | | | | | | | | | | | | | | | | |
| Meeting Dates/ Vergadering Datums | DRC/ URCSA | | | | | | | | | | | | | | | | | | | | | | | | | | | | | | |
| | <table border="1"> <thead> <tr> <th>Date</th> <th>DRC</th> <th>Joint DRC and URCSA</th> </tr> </thead> <tbody> <tr> <td>Friday, 29 January</td> <td>09:00-10:30</td> <td>10:30-12:00</td> </tr> <tr> <td>Friday, 26 February</td> <td>11:00-12:00</td> <td>12:00 13:00</td> </tr> <tr> <td>Friday, 26 March</td> <td>09:00-10:30</td> <td>10:30-12:00</td> </tr> <tr> <td>Friday, 23 April</td> <td>09:00-10:30</td> <td>10:30-12:00</td> </tr> <tr> <td>Friday, 21 May</td> <td>11:00-12:00</td> <td>12:00 13:00</td> </tr> <tr> <td>Friday, 23 July</td> <td>09:00-10:30</td> <td>10:30-12:00</td> </tr> <tr> <td>Friday, 27 August</td> <td>11:00-12:00</td> <td>12:00 13:00</td> </tr> <tr> <td>Friday, 1 October</td> <td>11:00-12:00</td> <td>12:00 13:00</td> </tr> <tr> <td>Friday, 5 November</td> <td>09:00-10:30</td> <td>10:30-12:00</td> </tr> </tbody> </table> | Date | DRC | Joint DRC and URCSA | Friday, 29 January | 09:00-10:30 | 10:30-12:00 | Friday, 26 February | 11:00-12:00 | 12:00 13:00 | Friday, 26 March | 09:00-10:30 | 10:30-12:00 | Friday, 23 April | 09:00-10:30 | 10:30-12:00 | Friday, 21 May | 11:00-12:00 | 12:00 13:00 | Friday, 23 July | 09:00-10:30 | 10:30-12:00 | Friday, 27 August | 11:00-12:00 | 12:00 13:00 | Friday, 1 October | 11:00-12:00 | 12:00 13:00 | Friday, 5 November | 09:00-10:30 | 10:30-12:00 |
| | Date | DRC | Joint DRC and URCSA | | | | | | | | | | | | | | | | | | | | | | | | | | | | |
| | Friday, 29 January | 09:00-10:30 | 10:30-12:00 | | | | | | | | | | | | | | | | | | | | | | | | | | | | |
| | Friday, 26 February | 11:00-12:00 | 12:00 13:00 | | | | | | | | | | | | | | | | | | | | | | | | | | | | |
| | Friday, 26 March | 09:00-10:30 | 10:30-12:00 | | | | | | | | | | | | | | | | | | | | | | | | | | | | |
| | Friday, 23 April | 09:00-10:30 | 10:30-12:00 | | | | | | | | | | | | | | | | | | | | | | | | | | | | |
| | Friday, 21 May | 11:00-12:00 | 12:00 13:00 | | | | | | | | | | | | | | | | | | | | | | | | | | | | |
| | Friday, 23 July | 09:00-10:30 | 10:30-12:00 | | | | | | | | | | | | | | | | | | | | | | | | | | | | |
| | Friday, 27 August | 11:00-12:00 | 12:00 13:00 | | | | | | | | | | | | | | | | | | | | | | | | | | | | |
| Friday, 1 October | 11:00-12:00 | 12:00 13:00 | | | | | | | | | | | | | | | | | | | | | | | | | | | | | |
| Friday, 5 November | 09:00-10:30 | 10:30-12:00 | | | | | | | | | | | | | | | | | | | | | | | | | | | | | |
| CURATORIUM 24 November (Wednesday) | | | | | | | | | | | | | | | | | | | | | | | | | | | | | | | |
| PROONENTS COMMISSION 22, 23 November (Monday, Tuesday) | | | | | | | | | | | | | | | | | | | | | | | | | | | | | | | |
| Admission 24 November (Wednesday) | | | | | | | | | | | | | | | | | | | | | | | | | | | | | | | |

2. Curatorium Uniting Reformed Church

Focus

The Curatorium is the church committee that oversees the theological training of URC students.

Dr N Philander acts as coordinator of all committees of the Curatorium, and further serves as contact person.

Staff

| | | |
|--|--|--|
| Acting Chair | Dr Mary-Ann Plaatjies van Huffel [Room 2011] Tel: 808-3255 E-mail: mapvanhuffel@sun.ac.za |  |
| Secretary and Pastoral mentoring of students | Dr Natie Philander Tel: 572 1805 [h] Cell: 083 2706 146 E-mail: wgk@sun.ac.za [Room 1005b] |  |
| Faculty Representative | Dr Xolile Simon [Room 2014] Tel. 808-3636 [w] E-mail: dsimon@sun.ac.za |  |

Committees

| COMMITTEE | ACTIVITIES |
|------------------------|---|
| Executive | Convenes on a monthly basis – deals with urgent matters on behalf of the Curatorium |
| Admission Committee | Responsible for the pastoral mentoring and evaluation of theological students in co-operation with the Executive Committee. |
| Bursary Committee | Responsible for annual awarding of bursaries and loans on behalf of the Curatorium. |
| Examinations Committee | <p>Responsible for the annual examinations for candidate ministers, reporting to the Curatorium</p> <p>The following applies to the final-year students for 2010:</p> <ul style="list-style-type: none"> • On 22 & 23 November 2010 the final year students that qualify will meet with the Examinations Committee to be officially admitted to the ministry during the ceremony that will be held on 24 November 2010. • All final-year students who want to be approved for ministry, should enquire as soon as possible at the Secretary of the Curatorium about the arrangements for their examination sermons. <p>It is the responsibility of students to enquire about the work to be examined by the Exam Committee.</p> |

3. Uniting Presbyterian Church of Southern Africa (UPCSA)

Staff

| | | |
|--------------------------------|--|--|
| Secretary | <p>Dr Eddie Germiquet Tel. 011-837 1258 [w] Tel. 011-837 1653 [fax] E-mail: ministry@presbyterian.org.za</p> |  |
| Pastoral mentoring of students | <p>Rev David Hunter Tel. 021-887 8572 [h] Tel. 021-887 0495[w] Cell: 083-702 1846 E-mail: cdhunter@adept.co.za</p> |  |
| | <p>Rev Dave Smit Tel. 021-685 6464/685 6115 [w] Tel. 021-671 4966 [h] Tel. 072-982 4181 [cell] Tel. 021-686 2824 [fax] E-mail : dave.renee@bigfoot.com</p> |  |

4. Church Liaison Council [CLCUS]

The Church Liaison Council of Stellenbosch University [CLCUS] represents the interests of the church partners whose students are trained at the faculty.

Contact persons

| | |
|-------------------------------|---|
| Dr Natie Philander | <p>Cell: 083 270 6146 E-mail: ugk@sun.ac.za</p> |
| Dr Coenie Burger | <p>Tel. 808 3382 E-mail: cwb@sun.ac.za</p> |
| Rev Monty Sahd (secretary) | <p>Tel 887 6819 E-mail: mpsahd@sun.ac.za</p> |

| | |
|------------------|---|
| Rev David Hunter | Rev David Hunter Tel. 021-887 0495[w] Tel. 021-887 8572 [h] Cell: 083-702 1846 E-mail: stellunited@adept.co.za |
|------------------|---|



Meeting Dates





| | | | |
|-------------------|--------------|-----------------|-----------------|
| 26 February 09:00 | 21 May 09:00 | 27 August 09:00 | 1 October 09:00 |
|-------------------|--------------|-----------------|-----------------|

11. Student Matters

1. Theological Students Council [TSC]

Executive and representation

| | | |
|---------------|---|---|
| Helené Fouché | Chairperson 0823399830 14839970@sun.ac.za |  |
| André Mostert | Vice-Chairperson 0731756098 15372286@sun.ac.za |  |
| Amos Petersen | Community Interaction 0761918867 15639517@sun.ac.za |  |

| | | |
|-------------------------|---|---|
| <p>Angelique Bester</p> | <p>Administrative Official 0839973867 15633551@sun.ac.za</p> |  |
| <p>Andrew Snyders</p> | <p>Spirituality and Diversity 0844538191 15801519@sun.ac.za</p> |  |
| <p>Enrico Beyers</p> | <p>Sport and Culture 0762363219 15481026@sun.ac.za</p> |  |
| <p>Eliznica Roux</p> | <p>Cafeteria 083520544 15883566@sun.ac.za</p> |  |
| <p>Hanzline Davids</p> | <p>Treasurer 0739260211 15147878@sun.ac.za</p> |  |

Contact details of TSC

Web page: www.sun.ac.za/theology/tsc.html

E-mail: tsktsc@sun.ac.za

General information

For the following you may consult the TSC Executive and/or your class representative, or alternatively, the notice boards:

- Grievances procedure
- Student matters
- Year programme
- Notices
- Meetings
- Krummelkring
- Other important matters
- Plagiarism procedure

2. Class Representatives

| YEAR GROUP | NAME | CONTACT | PHOTO |
|------------|-----------------|--------------------|---|
| BTh I | Fritz Kotze | 15793923@sun.ac.za |  |
| BTh II | Malcolm James | 13909754@sun.ac.za |  |
| BTh III | Niel Lambrechts | 15316548@sun.ac.za |  |
| BTh IV | Dawid Mouton | 15221377@sun.ac.za |  |

| | | | |
|------------|--------------------------|--------------------------|---|
| MDiv | Quentin Minnaar | 14875004@sun.ac.za |  |
| Lisensiaat | Hanneke Janse van Vuuren | hanneke@moederkerk.co.za |  |

3. Where are Our Lectures?

| YEAR GROUP | VENUE | ADDITIONAL REMARKS |
|------------------------|---------------------|---|
| BTh I | 2002 (Murray Hall) | <ul style="list-style-type: none"> o All Theology subjects are taken in Room 2002, except PT 114 [Wednesdays 08:00-11:00] that takes place in the Hofmeyr Hall [2003] first semester. o Arts subjects convene in the Arts building [as indicated by the different disciplines]. |
| BTh II | 2002 (Murray Hall) | <ul style="list-style-type: none"> o All Theology subjects are taken in Room 2002 [Murray Hall] except Eccl 234 [Mo 08:00; Wednesday 09:00; Thur 12:00] that takes place in [Room 1003] first semester. o Arts subjects convene in the Arts building [as indicated by the different disciplines]. |
| BTh III | 1003 | <ul style="list-style-type: none"> o All Theology subjects are taken in Room 1003 o Arts subjects convene in the Arts building [as indicated by the different disciplines]. |
| BTh IV | 1002 | <ul style="list-style-type: none"> o All Theology subjects are taken in Room 1002 o Arts subjects convene in the Arts building [as indicated by the different disciplines]. |
| MDiv | 1006 | <ul style="list-style-type: none"> o All classes are taken in Room 1006 o This venue is occasionally also used for other subjects. Reservations are made electronically in the office of the Dean's Secretary. |
| Licentiate | 2003 (Hofmeyr Hall) | For the majority of the year, this class group is busy with practical work in congregations. When they are present in the Faculty for contact weeks, Room 2003 is normally used except when double bookings with other activities occur. See the Licentiate programme where the venue reservations are indicated. |
| MTh Clinical Pastorate | 1003 | Every Thursday during the semester from 8:00 – 12:00. |

4. Tidiness of Venues

We urgently appeal to every student to keep venues neat. Each class representative must please take the responsibility to check:

- That chairs and tables are put in their original places;
- That no litter or dirty crockery are left in the class rooms;
- That the windows are closed properly after any lecture/meeting that takes place after lunch;
- That all lights are switched off;
- That the classroom is locked after use [if it was locked before use];
- No eating or drinking allowed in classrooms.

5. **Class Timetables** (Please note this timetable is according to the US module timetable. Changes made in class will not be reflected. Not all Arts and Humanities subjects are reflected here due to different group times.)

BTh Timetable 1st Semester 2010

| | Monday | | | | Tuesday | | | | Wednesday | | | | Thursday | | | | Friday | | | |
|--------------|--------------|--------------|-----------------------|--------|---------------------------|--------------|-----------------------|-------------|--------------|--------------|--------|--------|----------|----|------------------------|--------------------|--------------|--------------|--------------|--------------|
| | I | II | III | IV | I | II | III | IV | I | II | III | IV | I | II | III | IV | I | II | III | IV |
| 08h00 | ST 114 | | | | | NT 212 | ST 314 JEUJ 314 | PT 424 | PT 114 | Greek 212 | | ST 422 | | | BH 324 | | ST 114 | Greek 212 | | |
| 09h00 | | OT 212 | | | ST 122 | Greek 212 | ST 334 JEUJ 314 | PT 424 | PT 114 | Ecc1 234 | NT 322 | ST 422 | | | JEUJ 324 BH 324 | NT 414 | | Greek 222 | Greek 222 | Greek 324 |
| 10h00 | | OT 212 | ST 314 JEUJ 324 | PT 424 | | ST 222 | OT 322 JEUJ 314 | NT 414 | PT 114 | BH 212 | | OT 414 | | | | NT 414 | Greek 178 | Greek 222 | Greek 222 | Greek 324 |
| 11h00 | ST 114 | BH 212 | JEUJ 324 | OT 414 | | PT 214 | OT 322 BH 314 | Miss 414 | ST 122 | | ST 334 | OT 414 | | | NT 322 Greek 324 | | | NT 212 | NT 212 | ST 314 |
| 12h00 | ST 114 | Greek 222 | | PT 414 | | | ST 324 BH 314 | Miss 414 | | NT 212 | NT 352 | | | | NT 322 | ST 422 Miss 414 | ST 122 | NT 212 | NT 212 | ST 334 |
| 13h00 | BH 178(P) | | | | | | | | | (ST 222) | | | | | | | BH 178 | | | |
| 14h00 | | JEUJ 214 | OT 322/352 | PT 414 | Greek 178 | BH 222 | Greek 324 | | Greek 178 | PT 214 | | | | | ST 324 | | BH 178 | | | |
| 15h00 | | JEUJ 214 | ST 324 | PT 414 | Information Skills 178 | BH 222 | | | BH 178 | | | | | | | ST 222 | | | | |
| 16h00 | | JEUJ 214 | Greek 324 | | BH 178 | BH 222 | | | | ST 222 | | | | | | BH 212 | | | | |

BTh Timetable 2nd Semester 2010

| | Monday | | | | Tuesday | | | | Wednesday | | | | Thursday | | | | Friday | | | |
|--------------|----------|-----------------------|----------------------|--------|-----------|--------|------------------|--------|-----------|-----------|--------|----------|--------------------|-----------|---------------------|--------------------|-----------|-----------|-----------|----------|
| | I | II | III | IV | I | II | III | IV | I | II | III | IV | I | II | III | IV | I | II | III | IV |
| 08h00 | OT 144 | EkkI 242 | | | | | Miss 344 | PT 452 | EkkI 144 | | | EkkI 442 | | OT 242 | BH 354 | | OT 144 | Greek 242 | | |
| 09h00 | | OT 242 | JEUG 342 | | ST 143 | | ST 354 | | EkkI 144 | EkkI 242 | ST 344 | EkkI 442 | Greek 178 | PT 242 | BH 354 | NT 444 | | Greek 242 | | PT 444 |
| 10h00 | | OT 242 | Miss 344 JEUG 342 | PT 452 | JEUG 144 | ST 242 | ST 344 | NT 444 | | BH 242 | ST 354 | OT 444 | | PT 242 | | NT 444 Miss 444 | Greek 178 | | Greek 354 | |
| 11h00 | OT 144 | BH 242 | JEUG 342 | OT 444 | JEUG 144 | | BH 344 OT 352 | | ST 143 | | | OT 444 | JEUG 144 BH 178 | PT 242 | NT 352 Greek 354 | | | NT 242 | Miss 344 | PT 452 |
| 12h00 | EkkI 144 | JEUG 242 Greek 242 | | PT 444 | | | BH 344 OT 352 | PT 444 | | NT 242 | | | | | BH 344 OT 352 | | ST 143 | NT 242 | ST 354 | Miss 444 |
| 13h00 | BH 178 | Greek 252 | | | Greek 178 | | | | Greek 178 | | | | | Greek 252 | | | BH 178 | | | |
| 14h00 | | JEUG 242 | | | Greek 178 | BH 252 | Greek 354 | | | Greek 252 | | | | | Greek 354 | | BH 178 | | | |
| 15h00 | | JEUG 242 | ST 344 | | | BH 252 | | | BH 178 | | | | | | | | Greek 178 | ST 242 | | |
| 16h00 | | | Greek 354 | | BH 178 | BH 252 | | | | ST 242 | | | | | | | | | | |

Biblical Hebrew and Greek

| | | 1st Semester | | | | JUNE | | | | 2nd Semester | | | | NOVEMBER | |
|---------------------|------|--------------|--------|----------|----------|--------|--------|----------|----------|--------------|--------|----------|----------|----------|----------|
| Module | Eval | Test 1 | Test 2 | 1st Exam | 2nd exam | Test 1 | Test 2 | 1st Exam | 2nd exam | Test 1 | Test 2 | 1st Exam | 2nd exam | 1st Exam | 2nd exam |
| | Type | Date | Date | Date | Date | Date | Date | Date | Date | Date | Date | Date | Date | Date | Date |
| Biblical Hebrew 178 | de | 25 Mar | | 20 May | 09 Oct | | | 09 Oct | | | | 29 Oct | | 14:00 | |
| Biblical Hebrew 212 | de | 10 Mar | | 24 May | 19:00 | | | | | | | | | | |
| Biblical Hebrew 222 | de | 09 Apr | | 11 May | 19:00 | | | | | | | | | | |
| Biblical Hebrew 242 | de | | | | | | | 22 Sep | | | | 01 Nov | | 19:00 | |
| Biblical Hebrew 252 | de | | | | | | | 02 Oct | | | | 26 Oct | | 19:00 | |
| Biblical Hebrew 314 | de | 01 Mar | | 11 May | 09:00 | | | | | | | | | | |
| Biblical Hebrew 324 | de | 01 Mar | | 11 May | 09:00 | | | | | | | | | | |
| Biblical Hebrew 344 | de | | | | | | | 23 Aug | | | | 26 Oct | | 09:00 | |
| Biblical Hebrew 354 | de | | | | | | | 23 Aug | | | | 26 Oct | | 09:00 | |
| Greek 178 | de | 09 Apr | | 31 May | 19:00 | | | 26 Aug | | | | 01 Nov | | 19:00 | |
| Greek 212 | de | 24 Apr | | 20 May | 09:00 | | | | | | | | | | |
| Greek 222 | de | 01 Mar | | 14 May | 19:00 | | | | | | | | | | |
| Greek 242 | de | | | | | | | 02 Oct | | | | 04 Nov | | 09:00 | |
| Greek 252 | de | | | | | | | 15 Sep | | | | 15 Nov | | 19:00 | |
| Greek 314 | de | 01 Mar | | 18 May | 09:00 | | | | | | | | | | |
| Greek 324 | de | 05 Mar | | 11 May | 19:00 | | | | | | | | | | |
| Greek 344 | de | | | | | | | 13 Sep | | | | 29 Oct | | 09:00 | |
| Greek 354 | de | | | | | | | 25 Aug | | | | 26 Oct | | 19:00 | |
| Biblical Hebrew 178 | de | 25 Mar | | 20 May | 09:00 | | | 09 Oct | | | | 29 Oct | | 14:00 | |

7. General Arrangements regarding Assignments, Tests and Exams

- Lecturers will indicate timeously which assignments have to be done, when these should be handed in and what format they need to be in.
- Each assignment has to have the required signed declaration that it is the student's own work.
- All assignments should be handed in on time. The Faculty Board accepted the arrangement that assignments that are handed in late, will be penalized with 5% per day.
- Plagiarism, the use of someone else's work, without proper acknowledgement thereof, is a serious offence. The faculty has a zero tolerance policy in respect thereof. It is the responsibility of the student to know the Faculty and the University's full policy on plagiarism - ignorance will not be accepted as an excuse.
- If a student cannot write a test for some reason, he/she should contact the lecturer in advance to make alternative arrangements. In the case of illness, a medical certificate should be presented.
- All regulations of the University regarding examinations also apply to the Faculty of Theology.
- It is the responsibility of students to confirm test, exam schedules and venues.

8. Bible Knowledge Exam [for all DRC students]

All DRC students should please take note of the following:

- The Bible knowledge exam for all year groups will take place on Wednesday 21 July 2010 at 19:00 in the Faculty building.
- The following is prescribed for examination: Genesis - Joshua.
- More information can be obtained from Rev Monty Sahn.

9. Theology Library

Who are members?

All registered students and staff of the Faculty are automatically members of the library, as well as of the main library, the JS Gericke Library, and all the other branches.

Theology Library collection

The library collection includes a wide range of information on Christian Theology in the fields of Old and New Testament, Systematic Theology, Ecclesiology, Practical Theology and Missiology. The computer catalogue of the US Library Service [also accessible from outside the campus network] must be used to find material in the library. The catalogues of the other members of the Western Cape Library Consortium, CALICO, of which we are a member, can be reached at <http://www.calico.ac.za/calico/index.asp>.

Access to electronic databases, journals and books is possible through the web page of the US Library Service. ATLA/ATLAS is the most important database for theology, because it indexes only theology journals, as well as essays in books.

Material that is not available in the Library Service can be obtained from other libraries via the national and international interloan service. Information on this service is

available at the counter.

Services

The Theological Library provides its clients with a variety of services. Complete information is available on the SU Library Service website www.sun.ac.za/library. Click on Information about Library Services and on Libraries and collections and follow the links to the Theology Library.

Photocopying and computer printouts

Student/staff cards should be loaded at the Student Fees Counter in Admin A for laser printing in the Theology [or any other] library. At the beginning of the year, student cards are automatically credited with a certain amount for photocopying.

Library hours

During the Semester

Monday, Wednesday and Friday: 08:00 – 16:30

Tuesday and Thursday: 08:00 – 17:30

Saturday: 09:00 – 12:00 [except long week-ends]

Holiday Hours

Monday - Friday: 08:00 - 12:45 and 13:45 - 16:30

Saturday: Closed

The Theology Library is closed on all public holidays and between Christmas and New Year.

10. Photocopying

The photocopy machines in the photocopy room at the Library may be used by all students. Access and payment is possible by means of your student card [REMEMBER TO CANCEL THE CARD READER AFTER USE TO STOP OTHER PEOPLE FROM MAKING COPIES ON YOUR ACCOUNT]. Those who are not in possession of a student card, may ask at the Lending Desk of the Library to pay cash for their photocopying.

Please remember the following:

- There should always be silence in the copy room [not to disturb library users];
- The copy room should always be left tidy;
- Remember not to break the copyright laws;
- The photocopy machines in Mr Mark Koopman's room may not be used by students.

11. E-learning

E-learning is any teaching or study that takes place by means of electronic media, such as WebCT, PowerPoint, Video, Audio, etc.

The aim of e-learning is twofold: Firstly, new media is implemented in order to enrich the teaching and learning environment of the faculty. It is thus an aid to lecturers to

improve their teaching, as well as to students to improve their learning. Secondly, e-learning facilitates improved communication between students and lecturers, as well as amongst students. E-mail, discussion forums and other creative electronic means can be utilized towards this aim.

The main e-learning instrument in the faculty is Webstudies. WebCT, or Webstudies, provides the electronic space within which material can be made available to students, and within which discussions on the work can be facilitated. E-learning also stretches wider: any contribution by lecturers or students to the modules in electronic format can enrich the particular course. Students are therefore encouraged to bring along to the class any materials that they encounter on the internet, video, CD or DVD in order to contribute to our collection of electronic tools that may enrich our courses. E-learning creates, to a small extent, a research association within the faculty within which all can learn to discover.

It is the experience of students and lecturers alike that this tool enriches our teaching and learning process tremendously. Theology, the reading of texts, and the discussion of theology are enhanced. Course materials and notes are also more accessible, because these materials can be distributed electronically via WebCT [e.g. in PowerPoint format]. In some modules all electronic material is provided at the end of the semester to students on CD-Rom. All material can then be accessed in the process of preparing for tests and exams.

12. HUMARGA Computer Room

The Faculty of Theology has its own computer room, situated at the library. This computer room is a satellite of HUMARGA in the Arts building, and it is for the use of theology students [although other students are also allowed to make use of the facilities]. The computer area has 28 computers with full network connectivity.

The HUMARGA@Theology is available 24 hours per day. Technical assistance (from HUMARGA) is, however, only available from 08:00-17:00 every week day.

The following rules apply

- There should be silence at all times. This is a room for studying and working.
- The computers should be treated respectfully, and EVERYBODY is responsible for the security of the room. Please notify reception immediately of any strange behaviour or situation [and please stop anybody who is stealing a computer!!].
- No food or beverages are allowed in the room.
- No smoking is allowed in the room. A FIRE ALARM will go off. Trespassers will receive heavy fines.
- Every user must make sure that the room, as well as the toilet facilities, are kept tidy at all times. Please pick up your own papers, and tidy the bathroom after you have used it.
- Any trespassing could lead to suspension from the computer room. A security camera records all activities in the room. "Big [friendly] brother is watching you .."

13. Cafeteria

The Cafeteria on ground level in the Faculty, sells coffee, other refreshments and light meals. See the menu and price list in the Cafeteria. There are also tables [with umbrellas for shade in the summer] available in the enclosed square just outside the Cafeteria. Please keep this area tidy at all times.

14. Available Bursaries

The primary responsibility for the payment of study fees is upon the student. Each student needs to assure that he or she is able to pay for the programme he or she has registered for. Stellenbosch University and the Faculty of Theology acknowledge that some students may need assistance; however any assistance is limited and the students cannot look for financial support to the University and Faculty alone.

Application forms for undergraduate bursaries are distributed when new students arrive in February. Students, especially those from disadvantaged communities, are also strongly encouraged to apply to the University for financial assistance.

14.1. Bursaries/Loans of the DRC Curatorium

Please contact Mrs Estelle van der Merwe, Room 1013, tel: 887-6819 / 6828

The DRC Curatorium has the following bursaries:

| | |
|-----------------------|---|
| Study loans | The DRC Curatorium has a bursary fund for theological students who want to go into ministry. Awards from this fund are made on a loan basis, but when the student has finished his/her studies, and he/she is ordained in a congregation, half of the loan is written off as a bursary. During the study period no interest is calculated. However, after the end of the study period, interest is added. |
| Travel bursaries | Awarded to students that live further than 500km from Stellenbosch, at a rate of R1.50 per km to a maximum of R2500. |
| Merit bursaries | Awarded to students with an average year mark of higher than 70%. Bursaries are also awarded to students who achieve a good mark in the annual Bible knowledge exam. |
| Emergency fund | This fund is used to give financial assistance to very needy students in crisis situations. |
| Postgraduate students | Awards are made directly to postgraduate students: <ul style="list-style-type: none">• One-off awards are made to candidate ministers who want to further their studies directly after they have been admitted to ministry.• One-off awards at the conclusion of postgraduate study [R1 500 for MTh and R2 000 for DTh]. |

14.2. Bursaries/Loans of the URC Curatorium

The URC also has a bursary fund for students and enquiries can be made directly to them or to the Faculty reception.

14.3. Bursaries & Financial Assistance of the Faculty

The Faculty has a limited bursary budget made up of some individual bursaries with special conditions, and a general bursary fund. Any student first needs to approach the University's bursary (Under- and Postgraduate) offices for assistance.

Below are a list of the bursary funds available in the Faculty.

Kim Bursary Fund

This is a bursary fund sponsored by an alumnus Dr Kim.

Closing date: End of February

Criteria

- Full time students (under- and post graduate)
- Preference is given to students from previously disadvantaged groups and URCSA students)
- Application forms at Reception

General Bursary Fund

- This is a limited fund for financial assistance for students in dire need.
- Application forms at reception
- Applications can be made at any time of the year

OSP Bursary Fund- Postgraduate Students

The Overarching Strategic Plan (OSP) of the Faculty is the promotion of human dignity. Postgraduate students whose research is on human dignity can contact their promoters for further information about the OSP Bursary Fund.

15. Spiritual Development and Morning Meditation

The spiritual development of our theological students is important for the Faculty. Please note that early morning meditation services are held every morning, Monday to Friday from 7:30 to 8:00 in the Chapel.

Furthermore, each student is placed with a minister of a congregation from his/her particular church at the beginning of the year. These ministers act as spiritual mentors and are available for conversations. Support groups will be organized among the students in each class where the need should arise.

12. Schematic Representation of Programmes

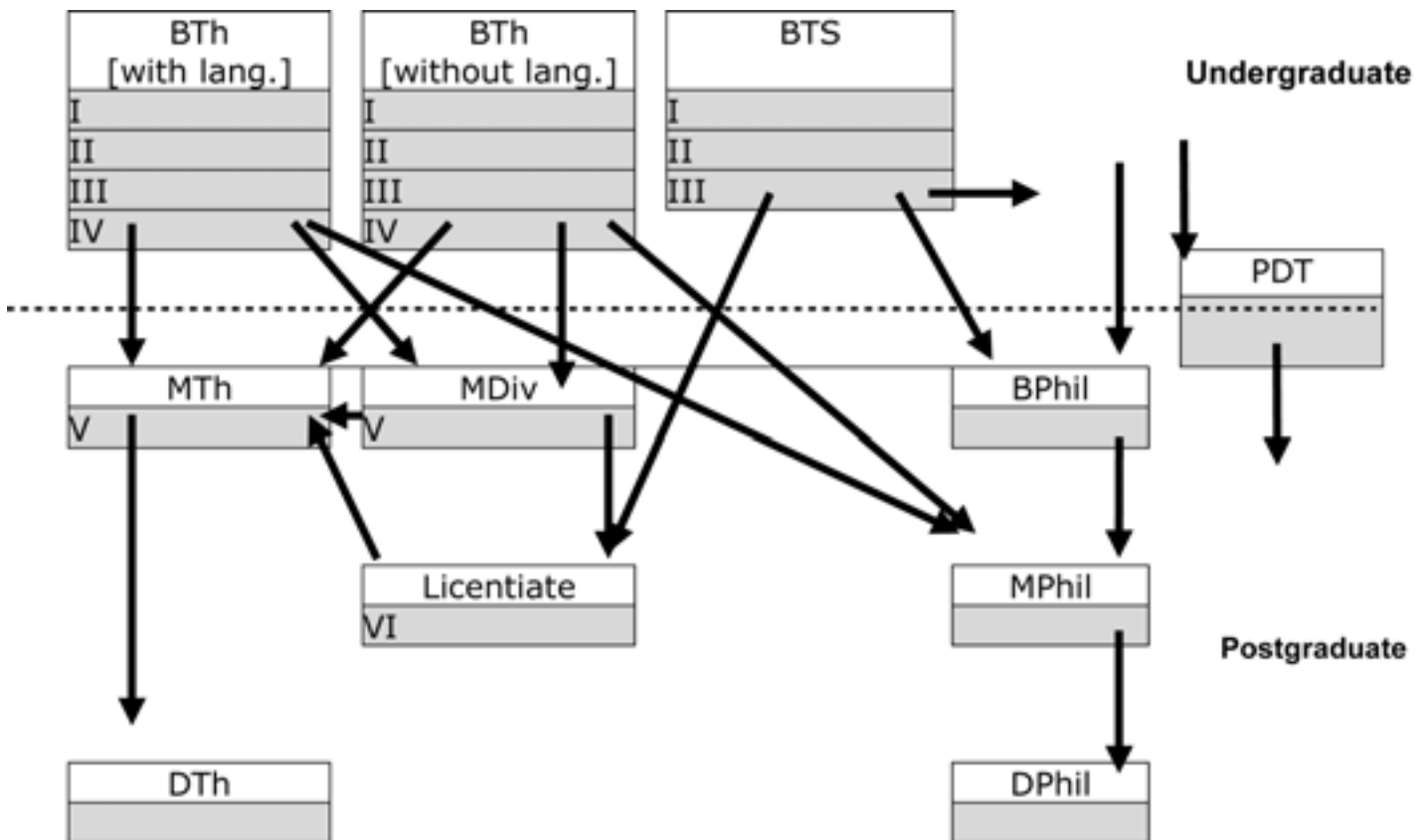

13. Undergraduate Programmes

1. General remarks

- What follows below is a short summary of the different programmes. For detailed information on subjects, please consult the Yearbook: Theology [Part 9].
- A credit is the amount of time [in hours] per week that the average student will dedicate to that specific module. The BTh programme requires appr. 50 hours per week.
- A programme [such as the BTh] is composed of a minimum of 120 credits per year.

2. BTh in Christian Theology, Church Ministry and Leadership [with Hebrew and Greek]

This four year programme is based upon a core curriculum that consists of

- i] Biblical Sciences and Theological Hermeneutics;
- ii] Christian Spirituality and Life-oriented Studies;
- iii] Communication and Community Service.

3. BTh in Christian Theology, Church Ministry and Leadership [without Hebrew and Greek]

This programme is the same as the previous, with the exception that the Biblical languages are not compulsory. In stead of the languages students may select additional subjects.

4. Baccalaureus in Theological Studies [BTS]

This programme provides a possible exit point at third year level for the four year BTh programme.

14. Postgraduate Programmes

1. General remarks

- What follows below is a short summary of the different programmes. For detailed information on subjects, please consult the Yearbook: Theology [Part 9].
- Postgraduate students are expected to be informed about the regulations and responsibilities prescribed by the University and the disciplines that apply to their study.

2. Postgraduate Diploma in Theology [PDT]

The primary aim of the Postgraduate Diploma is to prepare students who do not qualify for postgraduate studies for further theological studies. It also provides students with the opportunity to complement their previous studies with additional preparatory work before they start with postgraduate studies. For students from other disciplines it provides a broad overview of Theology in general.

For more detailed information, see the separate information booklet [provided by Practical Theology and Missiology], as well as the Yearbook.

3. MDiv

For more detailed information, see the separate information booklet [provided by Practical Theology and Missiology], as well as the Yearbook.

4. Licentiate in Theology

For more detailed information, see the separate Licentiate booklet [provided by Practical Theology and Missiology], as well as the Yearbook.

5. MTh programme

Masters studies can be done in any theological discipline. Apart from the more general Masters degrees in Theology, there are also a number of more applied MTh programmes [e.g. in Clinical Pastoral Care, Youth ministry, etc.]. Two variations are possible within the Masters programmes, namely a structured study [where mainly written/oral exams

are done on prescribed literature], or research [where a mini-thesis forms the major part of the study]. Normally, it is also a requirement that students should do exams in one or two subsidiary subjects.

For further information, please contact the particular department, or consult the Yearbook.

6. DTh programme

Doctoral studies can be done in any theological discipline. The study is concluded by means of a dissertation that is written under the guidance of a promoter. For further information, please contact the particular discipline group, or consult the Yearbook.

7. BPhil / MPhil / DPhil in Bible Interpretation

These programmes are jointly presented by the Dept of Ancient Studies [in the Arts Faculty] and Old and New Testament. It gives students with a B-degree in any non-theological discipline exposure to the Biblical sciences. Access is also possible via the different theological programmes [see diagram above].

For further information contact the Coordinator of the programme, Prof Louis Jonker [tel. 808-3268; lcj@sun.ac.za].

8. BPhil / MPhil in Chaplaincy

This is a joint programme of the Faculty of Theology and the Military Academy Saldanha. Candidates with a four year B-degree in Theology can apply. It is interdisciplinary with the following main modules:

- The Chaplain in the Military Environment
- Introduction to Military leadership
- The National and Military Security Environment
- General Management
- Research methodology
- Ethics in Public
- Diversity within Society
- Pastoral Care and Counselling principles
- Spirituality and the Healing of Life (Life skills)
- Organizational Development
- Communication and the Hermeneutics of Religious Texts.



For further information contact the co-ordinator of the programme, Dr Christo Thesnaar [tel. 808-3259; cht@sun.ac.za].

15. Units, Bureaus and Research Centres

1. Beyers Naudé Centre for Public Theology [BNC]

Web page: www.sun.ac.za/theology/bnc.htm

Staff

| | | |
|---|--|---|
| Director | Prof Nico Koopman [Room 2011] Tel: 808-3262 E-mail: nkoopman@sun.ac.za |  |
| Chair: Board of directors | Prof Dirkie Smit [Room 2010] Tel. 808-3258 [w] E-mail: djs1@sun.ac.za |  |
| Executive Manager (until the end of April) | Ms Anlené Taljaard [Room 1005c] Tel: 808 3250 E-mail: anlene@sun.ac.za |  |
| Researcher | Dr Robert Vosloo [Room 2006] Tel. 808 3256 [w] E-mail: rrvosloo@sun.ac.za |  |
| Editor: Beyers Naudé Publications | Mr Len Hansen [Room 1005c] Tel. 886 8669 [w] E-mail: ldhansen@sun.ac.za |  |

| | | |
|--------------------|--|---|
| Research assistant | <p>Mr Sipho Mahokoto [Room 2009] Cell: 083 745 3405 E-mail: mahokoto@sun.ac.za</p> |  |
| Researcher | <p>Dr Clint Le Bruyns Room 1005b Tel: 808-3250 E-mail: clb@sun.ac.za</p> |  |
| Researcher | <p>Dr Christoff Pauw SU International Office Tel: 808 4615 E-mail: cpauw@sun.ac.za</p> |  |
| Senior Researcher | <p>Prof Allan Boesak E-mail: boesak@mweb.co.za boesak@sun.ac.za Project: Globalisation</p> |  |
| Researcher | <p>Dr Lewellyn Macmaster Student Dean Tel: 808 2222 E-mail: lmacmast@sun.ac.za</p> |  |
| Researcher | <p>Dr Xolile Simon [Room 2013] Tel: 808 3636 E-mail: dsimon@sun.ac.za</p> |  |
| Researcher | <p>Dr Jan Nieder-Heitmann Vredelust Congregation Tel/ Fax: 021 913 2899 E-mail: niederheitmann@telkomsa.net</p> |  |

| | | |
|-------------------|---|---|
| <p>Researcher</p> | <p>Dr Chris Jones [Room 2045] Tel: 808 3624 E-mail: chrisjones@sun.ac.za</p> |  |
|-------------------|---|---|

Status

The Centre is a research and service institution of Stellenbosch University, situated in the discipline group Systematic Theology and Ecclesiology, and reporting to the Faculty Board of Theology.

Aim

To build, by means of research and service, capacity within the field of the role, task and responsibility of theology in the public arena.

Specific aims

- To do research on a project based on cooperation with partners within and outside the University concerning public theology.
- To disseminate the research results by means of national and international publications, conferences, symposia and workshops.
- To help generate publications that have a specific relationship to the Faculty of Theology.
- To do consultation and research, when contracted.
- To facilitate co-operation between the Faculty of Theology and the more general church communities, the ecumenical movements, national and international research and service institutions, as well as the public and private sectors.
- To present training in the form of short courses, seminars or similar initiatives.





Areas of Focus

The Centre is presently involved in the following areas of focus in co-operation with local and international partners:

- Human dignity and human rights
- Issues of faith and social identity
- Economic justice
- Responsible Citizenship
- Justice, peace and the integration of the Creation in global contexts

2. Ekklesia - Bureau for Continuing Theological Education and Research

Staff

| | | |
|--|---|---|
| Director and Coordinator of Research | Dr Coenie Burger Tel: 808-3624 E-mail: cwbu@sun.ac.za |  |
| Facilitation in congregations and Partnerships for Missional Churches (Communitas) | Dr Frederick Marais Tel: 808-3381 E-mail: jfm@sun.ac.za |  |
| Administrative officer | Ms Joanie Batt Tel: 808-3382 E-mail: jcab@sun.ac.za |  |
| Administrative officer | Ms Divine Robertson Tel: 808-3381 E-mail: dr@sun.ac.za |  |
| Administrative officer (Communitas) | Ms Chrisna van der Merwe Tel: 808-3624 E-mail: cmer@sun.ac.za |  |

| | | |
|--|---|---|
| Receptionist (Communitas) | Ms Sharon Naudé Tel: 808-3381 E-mail: snaude@sun.ac.za |  |
| Project manager: Research | Dr Cas Wepener Tel: 808-3264 E-mail: cwepener@sun.ac.za |  |
| Project manager: Network for Leadership facilitation | Dr Pierre Goosen Tel: 808 3382 E-mail: pmgoose@sun.ac.za |  |
| Office for Morality and Moral Leadership | Dr Chris Jones Tel: 808 3624 E-mail: chrisjones@sun.ac.za |  |

Contact details:

Ekklesia
1 Noordwal-wes Street
Stellenbosch, 7600
Postal address: PO Box 3322, Matieland 7602
Tel: + 27 21 808 3381
Fax: + 27 21 886 5701

Focus

Ekklesia (formerly BUCTER) is a bureau of Stellenbosch University that provides specialist services to ministers and congregations in co-operation with churches. We believe that congregations are God's gift to the world. Ekklesia wants to be a service centre where ministers and congregations can inspire and mentor one another in order to discover our calling in the service of the triune God anew.

Ekklesia identified the following 9 focus areas:

- Enriched faith in God and the Gospel that contributes to the renewal of teaching and preaching ... as well as open, friendly services where God can be experienced

- A koinonia ministry [small groups, friendships, relationships] by means of which members receive love, and by means of which they can be cared for and be empowered
- A strong family ministry
- Strong, loving and wise leadership [ministers, as well as leaders in congregations]
- Active ministry by members in and outside the congregation [gifts and calling]
- Functional structures and programmes
- Commitment to the Biblical calling of the church.

What do we do?

- We present a wide variety of courses for the development of dynamic leaders, inspired believers and active congregations.
- Thorough, practice-based research forms the backbone of the new insights and strategies that we develop.
- By means of our leadership development service we offer comprehensive support to ministers and congregations that want to be mentored on a local and individual level.
- Ekklesia offers a facilitation service to congregations by means of the facilitators and Society for Missional Congregations.
- Ekklesia wants to mobilize congregations in order to combat poverty.
- Ekklesia offers in cooperation with his partners a variety of workshops and conferences which are conducted by world leaders in different fields.
- We offer life-changing retreats that can be instrumental in the spiritual deepening of ministers and congregation leaders.
- We develop [and identify] a variety of reliable and relevant publications and programmes that can help congregations to cope with contemporary challenges.

3. Centre for Bible Interpretation and Translation in Africa [CEBITA]

Focus

The Centre is an interdisciplinary research and service institution of Stellenbosch University situated in the Dept of Ancient Studies and Old and New Testament, and reports to the faculty boards of Arts and Theology. The mission of the Centre is to coordinate and promote academic capacity in the field of Bible interpretation and translation by means of research and facilitation, in order to be of service to Bible interpreters and translators, particularly on the African continent.

Staff

| | | |
|-------------------------|--|---|
| Director and researcher | <p>Prof Louis Jonker Tel. 808-3268 E-mail: lcj@sun.ac.za</p> |  |
| Co-Researchers | <p>Prof Hendrik Bosman Tel. 808-3267 E-mail: hlb1@sun.ac.za</p> |  |
| | <p>Prof Christo van der Merwe Tel: 808-3655 E-mail: cvdm@sun.ac.za</p> |  |
| | <p>Prof Elna Mouton Tel. 808-3254 E-mail: emouton@sun.ac.za</p> |  |
| | <p>Prof Jeremy Punt Tel. 808-3626 E-mail: jpunt@sun.ac.za</p> |  |

| | | |
|--|------------------------------|---|
| <p>Post-doctoral Fellow (from 1 May)</p> | <p>Charlene van der Walt</p> |  |
|--|------------------------------|---|

Aims

- To do project-based research in co-operation with scholars from within and outside the University on relevant aspects in Bible interpretation, Bible translation, and reception of the Bible in general.
- In order to be practical in our approaches, to liaise with institutions which are involved in interpretation, translation or reception of the Bible [such as Bible translation agencies, training centres, churches, Bible study groups, or individuals] to determine their needs with regards to research, advice and practical assistance.
- To disseminate our research results by means of national and international academic publications, as well as through the presentation of symposia, workshops and/or conferences, and to present our results via popular publications for discussion in relevant and interested public forums.
- To formulate a framework for the equipment and training of Bible translators, as well as the mentoring of Bible translators in cooperation with institutions who are responsible for Bible translation in Africa, as well as with relevant departments at the University.
- To develop and maintain accessible computerized databases in the field of Bible interpretation, translation and reception in Africa in cooperation with existing national and international information retrieval programmes.
- To provide advice to interpreters, translators and users of the Bible, when requested.
- To develop practical translations and/or aids for the interpretation of specific Bible books on a project basis for specific reading audiences.

4. Unit for Religion and Development Research [URDR]

Focus

The Unit for Religion and Development Research [URDR] is a self-reliant entity [with academic status] within the structure of the Discipline Group Practical Theology and Missiology in the Faculty of Theology. The Unit reports to its Board and through the Board to the Faculty of Theology.

Staff

| | | |
|---|--|---|
| Director | Dr Ian Nell Tel: 8089094 E-mail: ianell@sun.ac.za |  |
| Researcher Programme manager: Training | Lisa le Roux Tel: 808-3577 E-mail: eleroux@sun.ac.za |  |
| Programme manager Capacity building, entrepreneurial skills | Ms Marietjie Botha Tel: 808-3577 E-mail: mjb@sun.ac.za |  |

Vision

To empower communities for sustainable development through research, theory development, training and consultation.

Mission

The URDR provides both research and training in the broad field of Community Development and Social Research, for the public, private, and academic sector. Thus the Unit aims to:

1. Do research regarding the development profile and –needs of local communities.
2. Do appropriate theory development
3. Offer a training and research facility to post graduate students both within the discipline of Theology and Development and other disciplines of the social sciences.
4. Offer professional research and training services to communities.
5. Communicate research results through scientific and popular publications.

5. Network for African Congregational Theology [NetACT]



E-mail: netact@sun.ac.za
Web: www.sun.ac.za/teologie/netact

Staff

| | | |
|---------------------|---|---|
| Executive director | Prof Jurgens Hendriks Tel: 8083260 E-mail: hjh@sun.ac.za |  |
| House Administrator | Christopher Munikwa Tel: 8829149 [w] Tel. 8866863 [h] [Room 2015b] |  |

Mission

NetACT is a network of theological institutions in Sub Saharan Africa, created and directed by these institutions, to assist them in preparing leaders for missional congregations.

NetACT's Major Goals

- Upgrade curriculum standards at our member institutions.
- Develop an effective system of communication, consultation and networking among all member institutions.
- Provide scholarships to advance the theological training of our institutions and lecturers.
- Create an affordable and welcoming living environment for lecturers who are receiving advanced training.
- Organise lecturer exchanges amongst our institutions to provide needed expertise, and to create space and time for lecturers to further their studies.
- Maintain an adequately staffed coordinating office.
- Publish theological handbooks relevant to the African context.
- Ensure that an HIV course is developed and maintained as a routine part of the

normal curriculum at each NetACT institution.

Chair: Rev. Dr D.T. Banda, Justo Mwale Theological College, PO Box 310199, Lusaka, Zambia. dtmbanda@gmail.com +260-97-7803740

Vice Chair: Dr Joseph Thipa; Zomba Theological College, PO Box 130, Zomba, MALAWI. josephthipa@yahoo.co.uk. (265)995250704

Secretary: Rev Henry Murray; The Principal, Murray Theological College, PO Morgenster, hensan@mango.zw Zimbabwe. 263 91-272-868 (cell)

Executive Director: Prof. H. Jurgens Hendriks, Department of Practical Theology and Missiology, Faculty of Theology, Stellenbosch University. hjh@sun.ac.za, +27218083260

Board Members:

Dr Devison T Banda (Justo Mwale Theological College, Lusaka, Zambia); Rev Joseph A Thipa (Zomba Theological College, Malawi); Prof Elna Mouton (Stellenbosch University); Prof Jurgens Hendriks (Stellenbosch University); Dr Ron Hartgerink, (South Haven MI, USA - representing donors); Rev Stephen J Chikoti (Josophat Mwale Theological Institution, Malawi); Rev Manasse Matiquele (Hefsiba, Mozambique); Rev Henry Murray (Murray Theological College, Zimbabwe); Rev Sam MacDonald (African Bible College, Malawi); Rev Thomas Togom (RITT, Kenya); Rev Simon Gilham (NETS, Namibia); Rev Rafael Avelino (ISTEL, Angola); Rev Alexandre dos Santos Mioco (ISEU, Angola).

Contact Details:

Address: NetACT, 171 Dorp Street, 7600 Stellenbosch, South Africa. <http://academic.sun.ac.za/theology/netact.html>

Tel & fax: +2721 882-9149; e-mail netact@sun.ac.za

Web: www.sun.ac.za/teologie/netact.html

16. Divisions of Centre for Student Counselling and Development (CSCD)

| Division within CSCD | CONTACT Person and Telephone Number |
|--|---|
| <ul style="list-style-type: none"> • Under- and post-graduate: change of degree programme; advice with regards to study possibilities, psychometric tests, academic support • Workshops: functional CV; professional interviewing; job hunting skills; career planning • Recruitment and Career Development Programme: Mock interview programmes; Recruitment and Career Development Programme; Resource centre (companies) | <p>For appointment for an individual session: Reception: Amanda Welgemoed, Desmond Fredericks 37 Victoria Street, Stellenbosch 808 4707 / 3027</p> <p>Workshops - Academic skills: www.sun.ac.za/workshops; workshops@sun.ac.za</p> <p>Workshops – Career development: Annette Joubert Careers office 808 3568</p> |

| | |
|--|---|
| <p>Office for Students with Special Learning Needs Support to students with special learning needs or disabilities</p> | <p>Head: Marcia Lyner-Cleophas (cleophas@sun.ac.za) 021 808 3497 Melanie Willems (mwillems@sun.ac.za) 021808 3675 Braille Officers: Connie Park (cdp@sun.ac.za) & Pippa Louw (phlouw@sun.ac.za) 808 3518</p> |
| <p>Individual and group therapy</p> <p>Workshops – e.g. Managing stress & anxiety, Assertiveness & social skills, Loss, etc.</p> | <p>Stellenbosch To make an appointment contact: Reception: Rakheenah Osman, 49 Victoria Street 021 808 4994;</p> <p>Tygerberg: Mumtaj Parker (Secretary: Laetitia) 021 938 9590</p> <p>Workshop registration workshops@sun.ac.za www.sun.ac.za/ workshops</p> |
| <p>Crisis Service:</p> <p>Service offered by CSCD professionals who can provide psychological assistance on short notice in times of crisis and trauma. Psychological crisis include the following: death of a close relative, suicide, accidents, rape, sexual harassment, depression, divorce, stressful situations/exams, severe relationship problems, etc.</p> | <p>The crisis number is: 082 557 0880 For direct contact: report to Victoria street 37 or 49, Stellenbosch, for assistance from staff.</p> |